

RIW Structureseal GPT External Corner

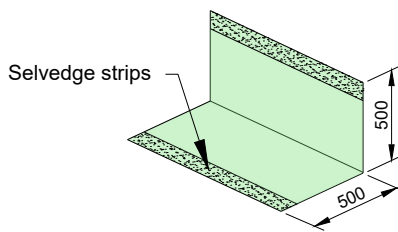

RIW Structureseal GPT Corner Strip

General Notes & Guidance:

This drawing must be read in conjunction with the latest RIW Product Literature.

All waterproofing details shown herein must receive approval from the design team or appointed designer before implementation on site, these waterproofing details may have other impacts on the structure and these impacts must be assessed and understood by the design team or appointed designer.

BS8102:2009

6.2.4 The need for continuity in the waterproofing protection should also be considered when selecting a type of protection. In most circumstances, the protection should be continuous.

Drawing Notes:

1. All gas membranes to be inspected and verified in accordance with Table 7 of BS8485:2015.
2. Ensure that any penetration details are sealed as per RIW's requirements. Please contact technical@riw.co.uk or 01753944200 for further assistance.
3. In certain circumstances it may be necessary to weld all laps, rather than using tapes. This may depend on ground conditions, validation requirements or installers preference.
4. Alternative detail must be agreed with the Design Engineer.

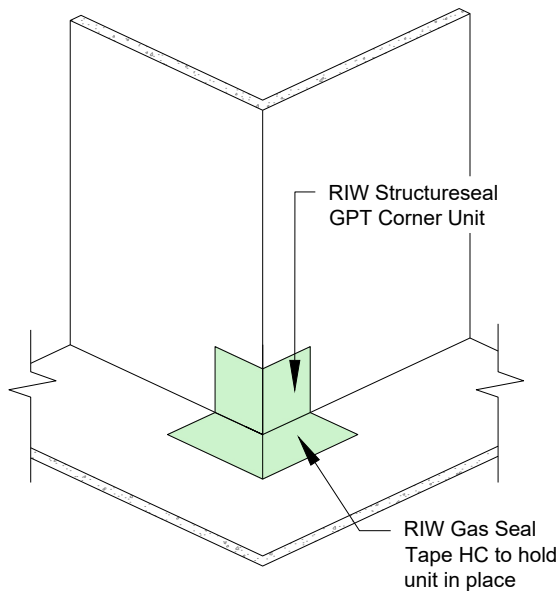

External Corner Stage 1

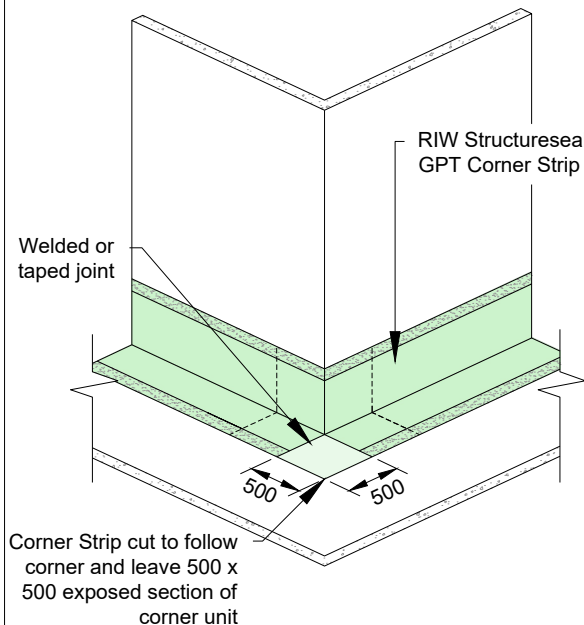

External Corner Stage 2

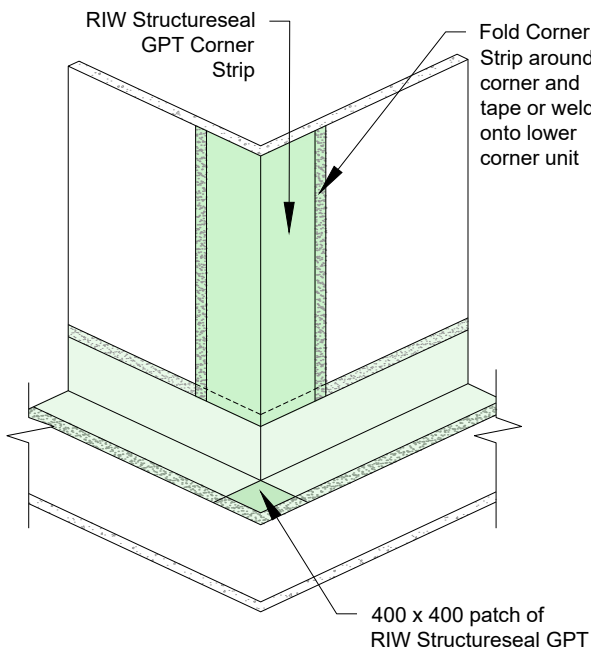

External Corner Stage 3

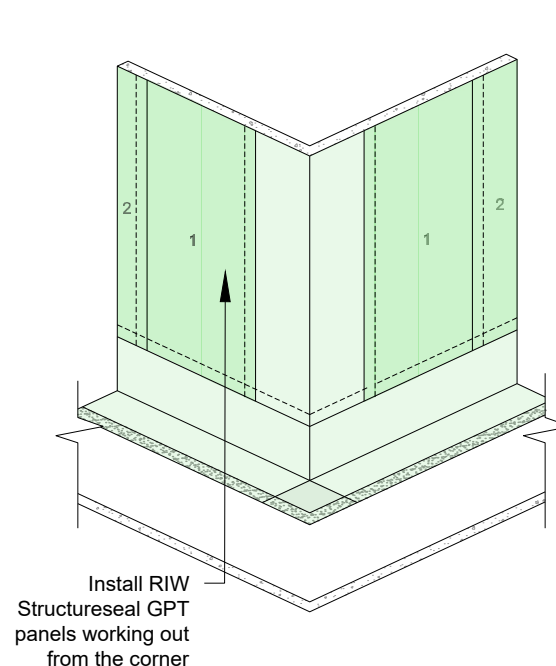

External Corner Stage 4

LAC® is a registered trademark of RIW Ltd. Flexiseal Pro, FWM, Heviseal, Toughseal, DPM Red, DPM Blue, Sheetseal 226, Structureseal, Cavitydrain R20, Cavitydrain R7, Gas Seal Black, Gas Seal HC, Sheetseal GR, Structureseal GPT, Sheetseal 9000, Cementjoint, Cementfill FC, Cementfill HB, Cementflex and Cementseal are all trademarks of RIW Ltd. Krystol Internal Membrane™ (Kim®), Krystol Waterstop Treatment™, Kyrtonite™ Swelling Waterstop and Krystol Waterstop Grout™, trademarks are the property of Kryton Inc.

This drawing is Copyright 2019 of RIW Ltd. Permission for copying is granted only to employees, authorised representatives, customers, and specifiers to support the sale or use of RIW Ltd products. All other rights are reserved.



RIW LTD

580 / 581 Ipswich Road, Slough, Berkshire, SL1 4EQ, UK
T: +44 (0) 1753 944200 E: technical@riw.co.uk W: www.riw.co.uk

Project:

Client:

Title:

RIW STRUCTURESEAL GPT:
EXTERNAL CORNER BUILD-UP

Additional Info:

Date:	Scale @ A4:	Drawn:	Checked:
19/09/19	NTS	RR	DK

Project Ref:	Drawing No:	Rev:
	RIW/TD/855	